



**IBM ARTIC960RxD Quad Digital Trunk  
PCI Adapter  
Installation and User's Guide**

## **Second Edition (March, 1999)**

**The following paragraph does not apply to the United Kingdom or any country where such provisions are inconsistent with local law:** THIS PUBLICATION IS PROVIDED "AS IS" WITHOUT WARRANTY OF ANY KIND, EITHER EXPRESS OR IMPLIED, INCLUDING, BUT NOT LIMITED TO, THE IMPLIED WARRANTIES OF MERCHANTABILITY OR FITNESS FOR A PARTICULAR PURPOSE. Some states do not allow disclaimer of express or implied warranties in certain transactions, therefore, this statement may not apply to you.

This publication could include technical inaccuracies or typographical errors. Changes are periodically made to the information herein; these changes will be incorporated in new editions of the publication. The manufacturer may make improvements and/or changes in the product(s) and/or the program(s) described in this publication at any time, without notice.

It is possible that this publication may contain reference to, or information about, products (machines and programs), programming, or services that are not announced in your country. Such references or information must not be construed to mean that these products, programming, or services will be announced in your country. Any reference to a specific licensed program in this publication is not intended to state or imply that you can use only that licensed program. You can use any functionally equivalent program instead.

Requests for technical information about products should be made to your authorized reseller or marketing representative.

**© International Business Machines Corporation 1998, 1999. All rights reserved.**

Note to U.S. Government Users -- Documentation related to restricted rights -- Use, duplication or disclosure is subject to restrictions set forth in GSA ADP Schedule Contract with IBM Corp.

---

## Contents

<b>Safety Information</b> . . . . .	v
<b>Handling Static Sensitive Devices</b> . . . . .	vii
<b>About This Book</b> . . . . .	ix
ISO 9000 . . . . .	ix
Related Information . . . . .	ix
Trademarks . . . . .	ix
<b>Chapter 1. Installation</b> . . . . .	1-1
Hardware Requirements . . . . .	1-1
IBM ARTIC960 Run Time Environment (RTE) Version 1.3 (or later) Support for AIX Installation . . . . .	1-2
Jumper Installation Information . . . . .	1-3
Installing the IBM ARTIC960RxD Quad Digital Trunk PCI Adapter . . . . .	1-4
Operating System Support . . . . .	1-9
<b>Chapter 2. Product Description</b> . . . . .	2-1
Part Numbers . . . . .	2-1
Features and Function . . . . .	2-2
Component Locations . . . . .	2-4
Specifications . . . . .	2-5
Optional Cables . . . . .	2-5
Operating System Support Programs and Publications . . . . .	2-5
<b>Chapter 3. Removing and Reinstalling the Quad T1/E1 DTA</b> . . . . .	3-1
Removing the Quad T1/E1 DTA . . . . .	3-1
Reinstalling the Quad T1/E1 DTA . . . . .	3-2
<b>Chapter 4. Installing the Device Driver on the RS/6000 SP System</b> . . . . .	4-1
Check System Pre-Requisites . . . . .	4-1
Install Software on the Control Workstation . . . . .	4-4
<b>Chapter 5. Troubleshooting</b> . . . . .	5-1
Problem Determination Procedures . . . . .	5-1
Diagnostic Testing . . . . .	5-1
Diagnostic Wrap Plugs . . . . .	5-2
<b>Chapter 6. Cables and Connectors</b> . . . . .	6-1
Port Speeds . . . . .	6-3
Connector Pin Numbers and Assignments . . . . .	6-4

<b>Appendix A. Communications Statements</b> . . . . .	A-1
Federal Communications Commission (FCC) Statement . . . . .	A-1
European Union (EU) Statement . . . . .	A-1
International Electrotechnical Commission (IEC) Statement . . . . .	A-2
United Kingdom Telecommunications Safety Requirements . . . . .	A-2
Avis de conformité aux normes du ministère des Communications du Canada . . . . .	A-2
Canadian Department of Communications Compliance Statement . . . . .	A-2
VCCI Statement . . . . .	A-3
Electromagnetic Interference (EMI) Statement - Taiwan . . . . .	A-3
Radio Protection for Germany . . . . .	A-4
Telecommunications Statements . . . . .	A-4
<b>Index</b> . . . . .	X-1
<b>Reader's Comments — We'd Like to Hear From You</b> . . . . .	X-3

---

## **Safety Information**

### **DANGER**

**An electrical outlet that is not correctly wired could place hazardous voltage on metal parts of the system or the devices that attach to the system. It is the responsibility of the customer to ensure that the outlet is correctly wired and grounded to prevent an electrical shock.**

**Before installing or removing signal cables, ensure that the power cables for the system unit and all attached devices are unplugged.**

**When adding or removing any additional devices to or from the system, ensure that the power cables for those devices are unplugged before the signal cables are connected. If possible, disconnect all power cables from the existing system before you add a device.**

**Use one hand, when possible, to connect or disconnect signal cables to prevent a possible shock from touching two surfaces with different electrical potentials.**

**During an electrical storm, do not connect cables for display stations, printers, telephones, or station protectors for communication lines.**



---

## Handling Static Sensitive Devices

**Attention:** Static electricity can damage this device and your system unit. To avoid damage, keep this device in its static protective bag until you are ready to install it. To reduce the possibility of electrostatic discharge, follow the precautions listed below:

- Limit your movement. Movement can cause static electricity to build up around you.
- Handle the device carefully, holding it by its edges or its frame.
- Do not touch solder joints, pins, or exposed printed circuitry.
- Do not leave the device where others can handle and possibly damage the device.
- While the device is still in its anti-static package, touch it to an unpainted metal part of the system unit for at least two seconds. (This drains static electricity from the package and from your body.)
- Remove the device from its package and install it directly into your system unit without setting it down. If it is necessary to set the device down, place it on its static-protective package. (If your device is an adapter, place it component-side up.) Do not place the device on your system unit cover or on a metal table.
- Take additional care when handling devices during cold weather, as heating reduces indoor humidity and increases static electricity.





---

## About This Book

This book describes the IBM ARTIC960RxD Quad Digital Trunk PCI Adapter. Use this information along with your system unit documentation to help install the adapter and device driver software.

### Terminology Note

Throughout this book, the IBM ARTIC960RxD Quad Digital Trunk PCI Adapter is referred to as the *IBM ARTIC960RxD Quad DTA*, the Quad T1/E1 DTA is referred to as the *mezzanine card*, and the IBM ARTIC960RxD PCI Adapter is referred to as the *base adapter*.

---

## ISO 9000

ISO 9000 registered quality systems were used in the development and manufacturing of this product.

---

## Related Information

This book refers to documentation that came with your system unit.

---

## Trademarks

AIX, RS/6000 and IBM are registered trademarks of International Business Machines Corporation.

Other company, product, and service names may be trademarks or service marks of others.



---

## Chapter 1. Installation

Each IBM ARTIC960RxD Quad DTA package includes the following:

- The IBM ARTIC960RxD PCI Adapter and Quad T1/E1 DTA pair
- This book (with Warranty Statement)

**Note:** The IBM ARTIC960RxD Quad DTA is a Class A device.

The Federal Communications Commission (FCC) classification for this product might differ from the FCC classification for your system unit. Use the classification that is highest. For example, if the FCC classification for your system unit is Class B and a card that you install is Class A, the classification of your system unit would change to Class A.

---

### Hardware Requirements

The IBM ARTIC960RxD Quad DTA requires a 32-bit, PCI slot. It can be installed in any PCI-compliant computer with a fixed frequency PCI bus clock, **Not spread-spectrum.**

---

## IBM ARTIC960 Run Time Environment (RTE) Version 1.3 (or later) Support for AIX Installation

The IBM ARTIC960 Run Time Environment (RTE) Version 1.3 (or later) Support for AIX must be installed on your system for the IBM ARTIC960RxD Quad DTA to function. This software is provided on the CD-ROM that came with this product. If your system is currently on, you may install the device drivers now. If your system is currently off, you may install the device drivers after installing the adapters.

**Note:** If you are using the RxD with the IBM DirectTalk for AIX (DT/AIX) software, the IBM ARTIC960 Run Time Environment (RTE) software (including the device drivers and RxD support) is installed automatically as part of the DirectTalk for AIX install process. Refer to the DT/AIX installation guide for further information.

To install the IBM ARTIC960 RTE Version 1.3 Support for AIX:

1. Turn on your system unit.
2. Log in as **root**.
3. Insert the CD-ROM into the CD-ROM drive.
4. At the command line, type `smitty devinst` and press **Enter**.
5. Press **F4**.
6. Select the CD-ROM option and press **Enter**.

**Note:** The installation will start. The message OK will display when the installation is completed.

7. If you are ready to install the adapter at this time:
  - a. Type `shutdown -F` and press **Enter** to shutdown your system.
  - b. Skip to "Jumper Installation Information" on page 1-3.
8. If you have already installed the adapter cards:
  - a. Type `shutdown -Fr` and press **Enter** to reboot your system.
  - b. Log in again as **root**. The adapters should now be configured and the system should be ready for use.

## Jumper Installation Information

Before installing this adapter, set jumper JP01 as follows:

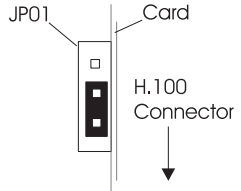
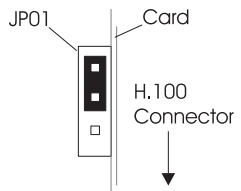
<i>Table 1-1. Jumper Installation Information</i>	
Jumper Positions	Condition
 <p>The diagram shows a vertical strip representing the JP01 jumper. It has three positions: a top square, a middle square, and a bottom square. The middle square is shaded black, indicating it is set. Labels include 'JP01' pointing to the strip, 'Card' pointing to the top edge, and 'H.100 Connector' with a downward arrow pointing to the bottom edge.</p>	<p>If the adapter to be installed is connected to either end of the H.100 Cable (see the illustration on page 1-5), the jumper must be installed as shown in the illustration to the left.</p> <p>If the adapter to be installed is the only IBM ARTIC960RxD in the system, then set the jumper as shown in the illustration to the left.</p> <p>This is the factory setting.</p>
 <p>The diagram shows a vertical strip representing the JP01 jumper. It has three positions: a top square, a middle square, and a bottom square. The top square is shaded black, indicating it is set. Labels include 'JP01' pointing to the strip, 'Card' pointing to the top edge, and 'H.100 Connector' with a downward arrow pointing to the bottom edge.</p>	<p>If the adapter to be installed is NOT connected to either end of the H.100 Cable (see the illustration on page 1-5), then set the jumper as shown in the illustration to the left.</p>

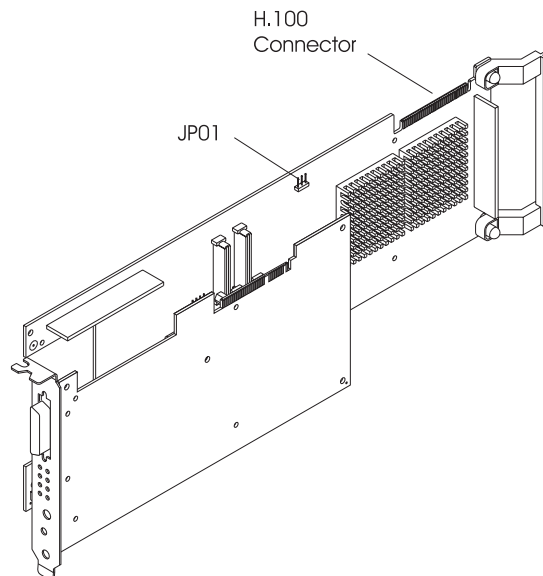

---

## Installing the IBM ARTIC960RxD Quad Digital Trunk PCI Adapter

The following procedure describes how to install the IBM ARTIC960RxD Quad DTA into the system unit. The steps may vary depending on your system unit. Refer to the documentation that came with your system unit for detailed instructions on performing the following procedures:

**Note:** Insure that the jumpers are set as described in “Jumper Installation Information” on page 1-3

- Be sure to perform necessary shutdown procedures to protect your system and data.
- Shut down your system unit
- Remove the system unit covers
- Install the IBM ARTIC960RxD Quad DTA into your system unit
- Install the H.100 cable if necessary
- Replace the system unit covers

## IBM ARTIC960RxD Quad Digital Trunk PCI Adapter Internal Cabling

Multi-drop cable assemblies are used to connect the internal busses on up to four Quad Digital Trunk PCI Adapters. There are three top card cables, RW, RX and RY. RW is used to connect multiple IBM ARTIC960RxD Quad DTAs to each other as well as other adapters with H.100 connectors, see below. Cables RX and RY are used to connect Quad DTAs or other adapters that have H.100 connectors as well as adapters that have SC-Bus connectors, see the following two pages.

These cables are just long enough to connect four adapters that support H.100 connectors in adjacent slots.

**H.100, 4-Drop Cabling:** The IBM ARTIC960RxD Quad DTAs have H.100 top card connectors.

The following figure illustrates the internal cabling for the IBM ARTIC960RxD Quad DTAs with the H.100 top card connectors cabled together. Up to four IBM ARTIC960RxD Quad DTAs are supported and must be in adjacent slots. Refer to Table 1-1 on page 1-3 to position the jumper on JP01 on the base card.

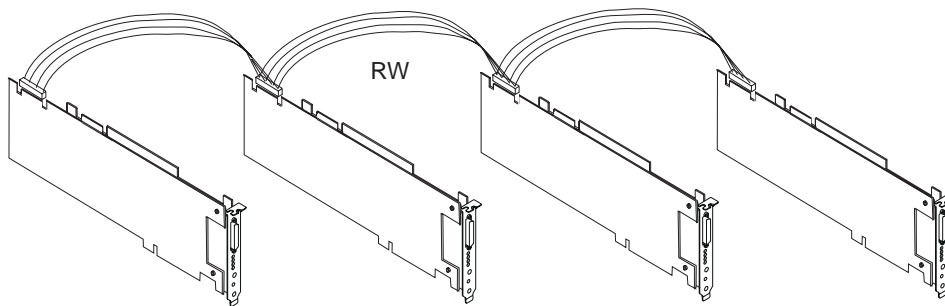

H.100, 4-Drop Ribbon Cabling

Cable Letter	Cable Name/ Description	Part Number	Feature Code	Length	
				m	ft
RW	H.100, 4-drop Internal Cable	08L1215	2877	0.127	0.417

**SC-Bus, 5-Drop Cable:** This Multi-drop cable assembly is used to connect up to four adapters with SC-Bus internal connectors. It has an additional SC-Bus connector which connects to cable RY. See “H.100, 4-Drop Cable With SC-Bus Converter Connector” on page 1-7. This allows adapters with SC-Bus connectors to be used with the IBM ARTIC960RxD Quad DTAs and with other adapters that have H.100 top card connectors.

The following figure illustrates the internal cabling for up to four adapters with SC-Busses and an additional SC-Bus connector which goes to the H.100 4-drop Cable with SC-Bus converter connector. Refer to Table 1-1 on page 1-3 to position the jumper on JP01 on the base card.

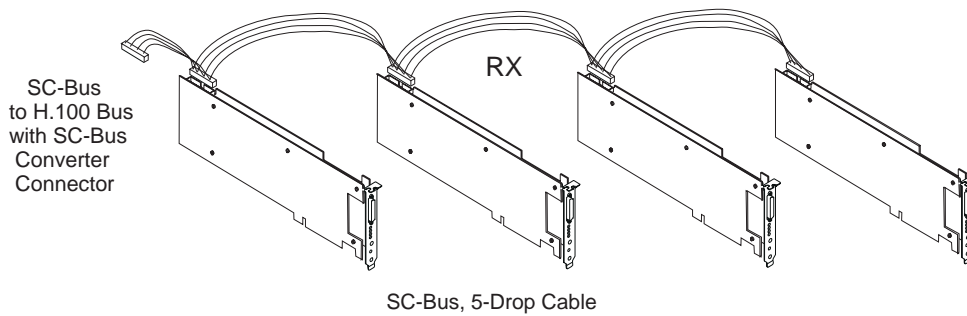

*Table 1-3. SC-Bus, 5-Drop Cable Information*

Cable Letter	Cable Name/ Description	Part Number	Feature Code	Length	
				m	ft
RX	SC-Bus, 5-Drop Cable	08L1217	2878	0.176	0.58



**H.100, 4-Drop Cable With SC-Bus Converter Connector:** This Multi-drop cable assembly is used to connect the internal busses on up to four IBM ARTIC960RxD Quad DTAs with H.100 connectors. It has an additional connector to connect to cable RX. See “SC-Bus, 5-Drop Cable” on page 1-6. This allows adapters with SC-Bus connectors to be used with the IBM ARTIC960RxD PCI Adapters and other adapters that have H.100 connectors.

The following figure illustrates the internal cabling for up to four IBM ARTIC960RxD Quad DTAs with an additional connector to the SC-Bus 5-drop cable with SC-Bus converter connector. Refer to Table 1-1 on page 1-3 to position the jumper on JP01 on the base card.

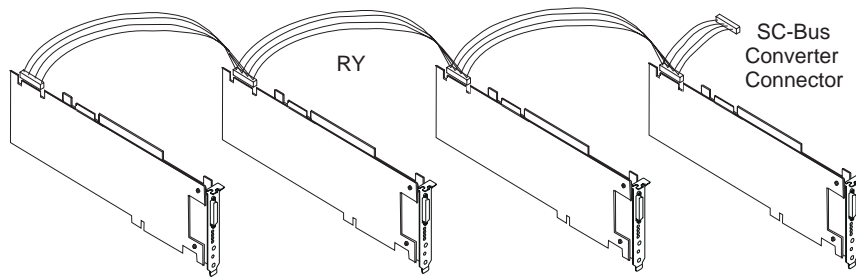

H.100, 4-Drop cable with SC-Bus Converter Connector

<i>Table 1-4. H.100, 4-Drop Cable with SC-Bus Converter Connector Cable Information</i>					
Cable Letter	Cable Name/ Description	Part Number	Feature Code	Length	
				m	ft
RY	H.100, 4-Drop Cable with SC-Bus Converter Connector	08L1219	2879	0.176	0.58

**Note:** This cable is referred to as the Four-drop, H.100 Cable with SC-Bus Converter in other publications associated with this cable.

## Connecting Telecommunications Cables

### Attention

Do not connect or handle the cable during a lightning storm.

The following instructions assume that you have the adapter in the system unit and are ready to attach an Telecommunications Cables.

1. Align the 36-pin connector of the cable with the 36-pin connector at the rear of the IBM ARTIC960RxD Quad DTA.
2. Depress the latch buttons on either side of the cable connector and firmly press the cable connector into the 36-pin connector.
3. Release the latch buttons and make sure that the cable connector latches are securely seated.

If required, connect a lightning protection device to the other ends of the cable. Refer to the instructions that came with the device.

At the very least, the grounding strap on the lightning protection device should be connected to an earth-ground on or near the computer.

4. Connect one or more of the four ports of the optional cable to the target device. Each connector is marked with its port number.

Telecommunications ports are numbered 0,1,2 and 3 whereas some software (such as DirectTalk/AIX) refers to the ports as 'Trunks 1,2,3 and 4'.

**Note:** Moving the system unit with a cable attached can dislodge an adapter. If any adapter or card becomes dislodged while power is applied, proceed as follows:

1. Turn off the computer and unplug all power cords.
2. Remove the system unit cover.
3. Loosen the expansion-slot screw of the dislodged adapter. Press down on the top edge of the adapter to reseat it. Then, re-tighten the expansion-slot screw.
4. Reinstall the system unit cover and replug power cords.
5. Turn on the computer.

---

## Operating System Support

If the DirectTalk for AIX software is used, the IBM ARTIC960 RTE is automatically installed as part of the DirectTalk for AIX installation. Proceed to Chapter 2.

### Downloading the Operating System Support Programs and Diagnostics

The adapter diagnostic program and the support programs for AIX can be obtained through the World Wide Web or a Bulletin Board System (BBS).

The IBM ARTIC960 Run Time Environment (RTE) Version 1.3 (or later) Support for AIX is shipped with the adapter.

**Downloading from the Web:** Do the following.

1. Using a Web browser of your choice, type:  
`http://wwprodsoln.bocaratn.ibm.com/artic/file\_rep.html`
2. Select the operating-system support you want.
3. Download the **Program** file.
4. Download the **Installation/file creation instructions** file, and follow the steps for installing and configuring the product support.

**Downloading from the BBS:** Do the following.

1. Check that your modem settings are as follows:

<b>Data Bit</b>	8
<b>Parity Bit</b>	N
<b>Stop Bit</b>	1

2. Dial the U.S.A. number **561-443-8222**.
3. Select the operating system support you want.
4. Select a **Transfer Protocol** supported by your communications software.
5. View on-line or download the **Readme/Instruction** file.
6. Follow the instructions in the readme file for downloading and installing the program support that comes with the diagnostics.

**Obtaining Operating System Software when Web/BBS Support Is**

**Unavailable:** For those who are unable to retrieve the files from either the Web or BBS, support is provided by telephone or E-mail.

For telephone assistance (U.S.A. ONLY), call:

**1-800-426-4968** and ask for technical support for the **IBM ARTIC960**.

For E-mail assistance, send to:

**artic@us.ibm.com**

---

## Chapter 2. Product Description

The IBM ARTIC960RxD Quad DTA is a full-size, 32-bit, PCI adapter. It consists of a base adapter (the IBM ARTIC960RxD PCI Adapter) and a mezzanine card (the Quad T1/E1 DTA).

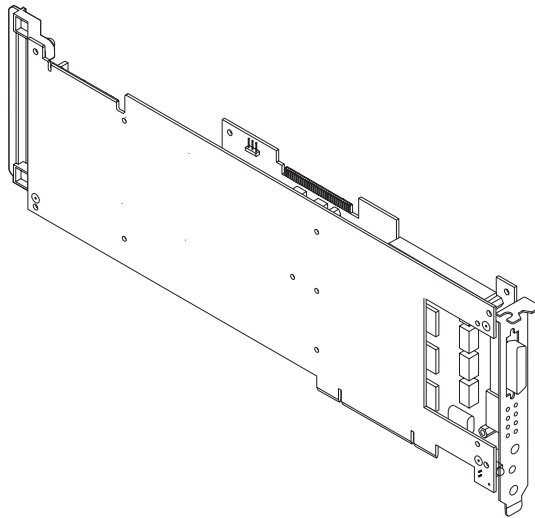

---

### Part Numbers

The following table lists the part numbers for the field-replaceable units (FRUs) associated with this adapter.

Description	Part Number
IBM ARTIC960RxD PCI Adapter	87H3734
Quad T1/E1 DTA (includes the adapter bracket)	09J8829

---

## Features and Function

These sections describe the base adapter and the mezzanine card.

### IBM ARTIC960RxD PCI Adapter—Base Adapter

The base adapter provides high-function control of I/O operations and serves to off-load input/output tasks from the system microprocessor. The base adapter has the following standard features:

- An Intel 80960RD processor (clock-doubled RP) running at up to 33 MHz (depends on the PCI clock on the system bus)
- On-board memory, which is available only to the processor on the base adapter and cannot be accessed through the system bus.
  - 4 MB extended-data-output (EDO) dynamic random-access memory (DRAM)
  - Flash read-only memory (ROM)
- A 32-bit system-bus PCI interface
- Two Texas Instruments TMS320C6201 digital signal processors (DSPs), operating at a clock cycle of 200 MHz. Each DSP has 512 KB of synchronous-burst static random-access memory (SBSRAM) and can process up to 1 600 000 000 instructions per second.
- A PLX technology 9080, which provides the 80960RD processor with access to the SC4000s and DSPs using memory-mapped I/O and DMA access.
- Two VLSI VP06967 SC4000 chips, which provide an interface to the H.100 connector. One chip provides an interface between the DSPs and the H.100 connector; the other provides an interface between the mezzanine card and the H.100 connector.
- An ECTF H.100 connector operating in SC-bus compatible mode
- PMC connectors, which support attaching any mezzanine card with a PCI mezzanine card (PMC) interface

## **IBM Quad T1/E1 DTA—Mezzanine Card**

The mezzanine card provides an interface to four T1 or E1 external network trunk lines.

The mezzanine card has the following features:

- A PMC bus interface to the base adapter
- Four Siemens PEB2255-LH framing and line control (FALC) chips, which provide the interface functions for the four trunk lines
- A PLX Technology 9050 chip, which provides an interface from the PMC bus to the FALC and SC4000 chips
- A VLSI VP06967 SC4000 chip, which provides an interface from the FALCs to the H.100 connector. This feature is used only in non-DSP line-interface applications.
- An ECTF H.100 connector operating in SC-bus compatible mode. This feature is used only in non-DSP line-interface applications.
- Passive components and a 36-pin connector, which allow the FALCs to interface to the four external trunks
- A relay, which can be used for an external alarm or indicator

---

## Component Locations

The following shows some component locations on the IBM ARTIC960RxD Quad DTA.

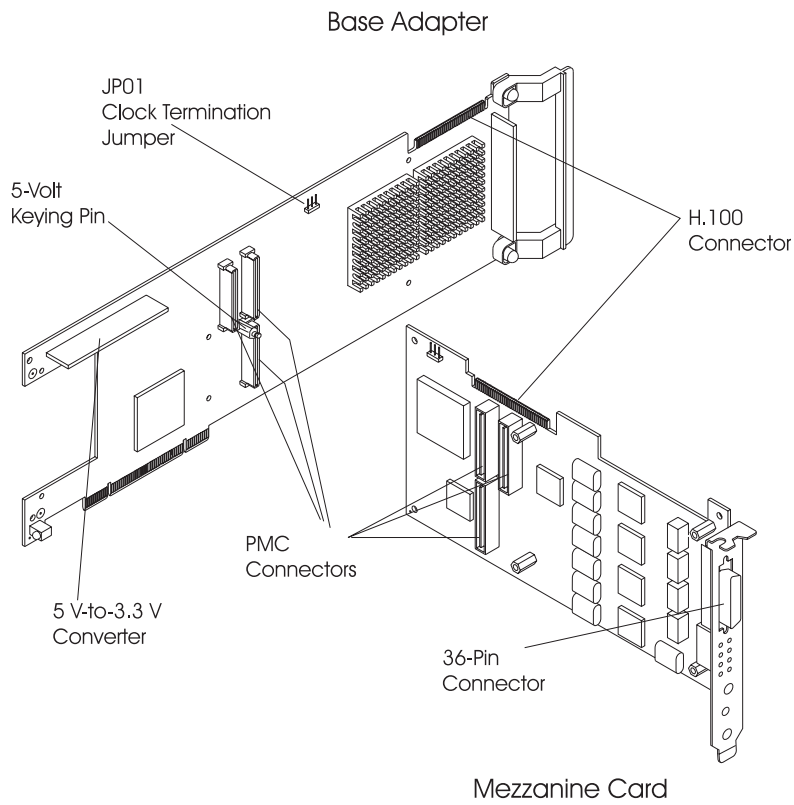



---

## Specifications

The following describes the physical attributes, environmental conditions, and electrical requirements for the adapter.

### **Size**

Length: 350 millimeters (13.75 inches)

Height: 131 millimeters (5 inches)

### **Environment**

- Air Temperature:

Operating: 0°C through 55°C (32°F through 131°F)

Non-Operating: -40°C through 60°C (-40.°F through 140°F)

- Humidity:

Operating: 5% through 95%.

Wet Bulb Temperature: 29°C (84.2°F)

### **Electrical**

- Power Requirements

+3.3 V dc, 0 A

+5 V dc, 4.0 A (maximum)

+12 V dc, 0 A

-12 V dc, 0 A

---

## Optional Cables

Optional cable assemblies are available for the IBM ARTIC960RxD Quad DTA. See Chapter 6, "Cables and Connectors" for information.

---

## Operating System Support Programs and Publications

To help programmers develop additional applications for the IBM ARTIC960RxD Quad DTA, a set of operating system packages containing the drivers and utilities to support a particular operating system is available on the World Wide Web (Web). To download from the Web, see "Operating System Support" on page 1-9.

The IBM ARTIC960 Run Time Environment (RTE) Version 1.3 (or later) Support for AIX is shipped with adapter.



---

## Chapter 3. Removing and Reinstalling the Quad T1/E1 DTA

This chapter contains information on removing and reinstalling the Quad T1/E1 DTA from the base adapter. In this section, the IBM ARTIC960RxD PCI Adapter is referred to as the base adapter, and the Quad T1/E1 DTA is referred to as the mezzanine card.

---

### Removing the Quad T1/E1 DTA

The following procedure describes how to remove the mezzanine card from the base adapter. The procedure varies depending on your system unit. Refer to the documentation that came with your system unit for detailed instructions on performing the following procedures:

- Shutting down your system unit
- Removing the system unit covers
- Removing an adapter from the system unit

**Note:**

- Be sure to hold the IBM ARTIC960RxD Quad DTA by the edges only; do not touch the component pins or solder joints.
- If more than one adapter is installed, remove the H.100 cable and note the state of JP01.

1. Remove the four mounting screws from the base adapter as shown in the following figure. (The two cards are still held together by the PMC connector.)

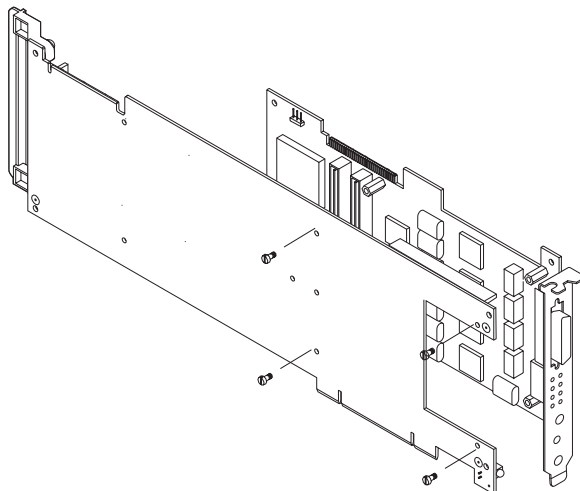

2. Carefully separate the connector on the mezzanine card from the connector on the base adapter using a gentle rocking motion.

---

## Reinstalling the Quad T1/E1 DTA

The following instructions assume that you have the base adapter out of the system unit and are ready to install the mezzanine card.

### Before You Begin

Verify that the jumper on the base adapter is set properly (see page 1-3).

1. Align the connector on the mezzanine card with the PMC connector on the base adapter.

**Attention:**

When the base adapter and the mezzanine card are properly aligned, the top of the voltage keying pin on the base adapter fits into the voltage key opening on the mezzanine card.

2. Firmly press the mezzanine card and the base adapter connectors together.

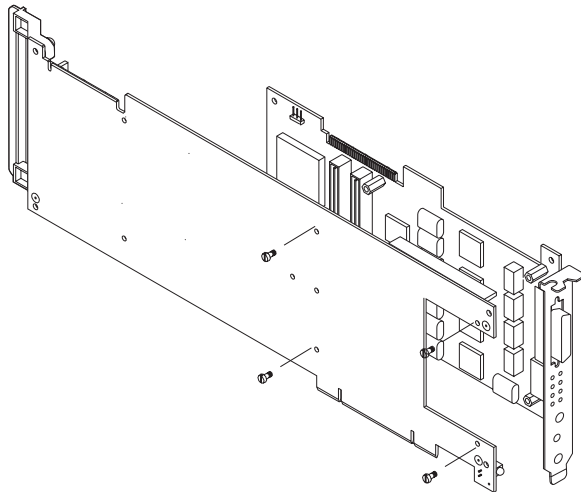

3. Install the four mounting screws; then tighten the screws.
4. Follow the procedure "Jumper Installation Information" on page 1-3.

---

## Chapter 4. Installing the Device Driver on the RS/6000 SP System

In an SP, you need to do on each node what you normally do on a standalone system. You must make the installation files available and then install them on all the relevant nodes.

Perform the following tasks on the Control Workstation. You should not need to **telnet** or **rlogin** to the individual SP nodes. You need to be familiar with the **dsh** command. If not, refer to the *Parallel System Support Program for AIX: Administration Guide* or *Parallel System Support Program for AIX: Command and Technical Reference*.

If you are unable to utilize the "dsh" command because of the setup at your site, then you will have to telnet to each node and perform the steps below, omitting the "dsh" prefix.

---

### Check System Pre-Requisites

\_\_\_ 1. Log into the Control Workstation as a **root**.

\_\_\_ 2. Go to a temporary directory by typing:

```
cd /tmp
```

at the system prompt, then press Enter.

\_\_\_ 3. Make a "working collective" file containing a list of the relevant nodes on which you want to perform the update in preparation for the dsh command. Type the following, press Enter after each line:

```
cat > group1
nodename1
nodename2
nodename3.....
CTRL-D
export WCOLL=/tmp/group1
```

\_\_\_ 4. Test the working collective by typing:

```
dsh date
```

then press Enter. The results should look similar to:

```
nodename1: Wed Apr 10 10:37:46 EDT 1996
nodename2: Wed Apr 10 10:37:46 EDT 1996
nodename3: Wed Apr 10 10:37:47 EDT 1996
nodename4: Wed Apr 10 10:37:48 EDT 1996
```

If not, examine your nodelist file `./group1` and also ensure that the Kerberos ticket is current to permit "rsh" to be performed. If not, you may need to refresh it. The System Administrator should also be able to help you with Kerberos initialization. If not, consult your support center.

If you only need to do a few nodes, use the `dsh -w host1,host2,host3...` command format to explicitly exercise groups of nodes rather than using the working collective.

- \_\_\_ 5. Determine if the AIX operating system on each relevant node is at the required level by typing:

```
dsh oslevel
```

-OR -

```
dsh -w <host1,host2> oslevel
```

at the prompt, then press Enter. `<host1,host2>` is a list of the hostnames for the nodes which the adapter will be installed on.

- \_\_\_ 6. The required AIX Level is: 4.2.1 and higher.

If the nodes are NOT at a supported AIX level, upgrade the AIX level on the nodes. Contact the System Administrator for assistance.

- \_\_\_ 7. Determine if the PSSP level on each node is at the required level by typing:

```
/usr/lpp/ssp/bin/splstdata -G -b
```

then press Enter. The results are in a form similar to the following:

```
node#      hostname  hdw_enet_addr  srvr    response  install_disk
last_install_image  last_install_time  next_install_image  lppsource_name
                                           pssp_ver
-----
1 eion01.ppd.pok.i  08005A75A6D4    0        disk      hdisk0
      default Thu_Dec__4_09:07:23      default <lppsource>
                                           <pssp level>
```

`<lppsource>` is the lppsource name for the node. `<pssp level>` is the pssp level installed on the node.

- \_\_\_ 8. The required PSSP level is: 2.4 and higher.

If the nodes are NOT at a supported PSSP level, upgrade the PSSP level on the nodes. Contact the System Administrator for help.

- \_\_\_ 9. Record the name that appears below `lppsource_name` for each node on which the adapters are being installed; you use this later.
- 
- \_\_\_ 10. Check if the device driver is installed in the `lppsource` directory by typing:
- ```
cd /spdata/sys1/install/<lppsource_name>/lppsource
```
- at the system prompt. `<lppsource_name>` was recorded in the previous step. Once in this directory, type:
- ```
ls devices.artic960*
```
- at the system prompt to see if the fileset is in `lppsource` directory.
- \_\_\_ 11. If the device driver is not in the `lppsource` directory, proceed to section “Install Software on the Control Workstation” on page 4-4 to install the software.
- \_\_\_ 12. Update the SPOT (Shared Product Object Tree) by:
- \_\_\_ a. Type
 

```
smitty nim_res_op
```

 at the system prompt. The **Resource Name** panel displays with
 

```
boot          resources  boot
```

 highlighted.
  - \_\_\_ b. Move the cursor down until the *SPOT resource* is highlighted. The *SPOT resource* should look like:
 

```
spot_AIX432  resources  spot
```

 The format of the spot name is: `spot_<lppsource_name>`.  
`<lppsource_name>` was recorded in a previous step.
  - \_\_\_ c. When the *SPOT resource* is highlighted, press Enter to select this option. The **Network Install Operation to Perform** panel displays with the **reset** option highlighted for selection.
  - \_\_\_ d. Move the cursor until the **cust** option is highlighted and press Enter to select this option. The **Customize a SPOT panel** displays with the **Source of Install Images** highlighted for selection.
  - \_\_\_ e. Press F4 to display the list of Install Images and select the appropriate `lppsource`.
  - \_\_\_ f. Move the cursor until the appropriate `lppsource` is displayed. For example:
 

```
lppsource_AIX432  resources  lpp_source
```

- \_\_\_ g. Move the cursor until the **fileset names** and type:  
     `devices.artic960`
- \_\_\_ h. Press Enter to start the SPOT update. This operation can take up to 15 minutes.
- \_\_\_ 13. Check if the software is already installed by typing:  
     `dsh "lslpp -l devices.artic960* 2>&1" |more`  
     at the system prompt.
- \_\_\_ 14. If the device driver is already installed on the Node, contact your service provider to have the adapter installed.
- \_\_\_ 15. If the device driver is not installed on the Node, proceed to section "Install Device Drivers on the SP Nodes" on page 4-6.

---

## Install Software on the Control Workstation

**Note:** If your system is "partitioned" i.e. there are more than one operating system among the nodes, you may **only** install this adapter in nodes that have **4.2.1 and higher**.

- \_\_\_ 1. If you are not logged into the Control Workstation as a root user, log in now. You may also need to export the working collective. Refer to section "Check System Pre-Requisites" on page 4-1.
- \_\_\_ 2. Select the appropriate operating system media.

<i>Table 4-1. Device Driver Sources</i>	
AIX 4.3.x	IBM ARTIC960 RTE Disk Kit
AIX 4.2.1	IBM ARTIC960 RTE Disk Kit

- \_\_\_ 3. Insert the installation media into the Control Workstation's drive.
- \_\_\_ 4. Transfer the files to the Control Workstation's lppsource, as follows:
  - \_\_\_ a. Type  
     `smitty bffcreate`  
     then press Enter.
  - \_\_\_ b. Select the input device/directory. Press F4 then move the cursor to the appropriate input device and press Enter.



- \_\_\_ c. Move the cursor to the "SOFTWARE package to copy" option and press F4 to select the software to be installed. Use the F7 key to select the following device driver(s):
  - No Prerequisite Driver
  - devices.artic960
 at the system prompt, then press Enter.
- \_\_\_ d. Move the cursor down to "DIRECTORY for storing software package" and enter the appropriate lppsource destination directory:
  - /spdata/sys1/install/<lppsource\_name>/lppsource
 using the <lppsource\_name> you recorded earlier.
- \_\_\_ e. Press Enter to begin copying the files.
  - Note:** This step may take several minutes as the directory table of contents is updated.
- \_\_\_ 5. Update the SPOT (Shared Product Object Tree) by:
  - \_\_\_ a. Type
    - smitty nim\_res\_op
 at the system prompt. The **Resource Name** panel displays with
    - boot            resources    boot
 highlighted.
  - \_\_\_ b. Move the cursor down until the *SPOT resource* is highlighted. The *SPOT resource* should look like:
    - spot\_AIX432    resources    spot
 The format of the spot name is: spot\_<lppsource\_name>. <lppsource\_name> was recorded in a previous step.
  - \_\_\_ c. When the *SPOT resource* is highlighted, press Enter to select this option. The **Network Install Operation to Perform** panel displays with the **reset** option highlighted for selection.
  - \_\_\_ d. Move the cursor until the **cust** option is highlighted and press Enter to select this option. The **Customize a SPOT panel** displays with the **Source of Install Images** highlighted for selection.
  - \_\_\_ e. Press F4 to display the list of Install Images and select the appropriate lppsource.
  - \_\_\_ f. Move the cursor until the appropriate **lppsource** is displayed. For example:
    - lppsource\_AIX432    resources    lpp\_source

- \_\_\_ g. Move the cursor until the **fileset names** and type:  
    `devices.artic960`
- \_\_\_ h. Press Enter to start the SPOT update. This operation can take up to 15 minutes.
- \_\_\_ 6. Proceed to section "Install Device Drivers on the SP Nodes"

### Install Device Drivers on the SP Nodes

- \_\_\_ 1. Make sure that the lppsource directory is exported to the Nodes by typing:  
    `showmount -e`  
    at the system prompt. The result should be something of the form:  
    `/spdata/sys1/install/AIX432/lppsource (everyone)`
- \_\_\_ 2. If the directory is not exported, you may temporarily export the directory by typing:  
    `exportfs -i /spdata/sys1/install/<lppsource_name>/lppsource`
- \_\_\_ 3. NFS Mount the lppsource directory by typing:  
    `dsh mount <controlwks>:`  
  
    `/spdata/sys1/install/<lppsource_name>/lppsource /mnt`  
    at the system prompt. `<controlwks>` is the name of the Control Workstation known for the Nodes. `<lppsource_name>` is the name you recorded earlier in section "Check System Pre-Requisites" on page 4-1.
- \_\_\_ 4. Perform a preview of the files to be installed on the nodes by typing:  
    `dsh "installp -p -acqXd /mnt device driver 2>&1" | more`  
    at the system prompt. *device driver* is the filesets that must be installed for the adapter. The list includes:
  - No Prerequisite Driver
  - `devices.artic960`
- \_\_\_ 5. Then perform the device driver installation by typing:  
    `dsh "installp -acqXd /mnt device driver 2>&1" | more`  
    at the system prompt. *device driver* is defined in the previous step.
- \_\_\_ 6. If the device driver is already installed on the node, contact your service provider to have the adapter installed.

---

## **Chapter 5. Troubleshooting**

This chapter discusses how to troubleshoot possible problems with the base adapter.

If the DirectTalk for AIX is installed follow the steps in the DirectTalk for AIX guide for running diagnostics.

---

### **Problem Determination Procedures**

For system testing information, refer to the documentation that came with your computer.

If you performed the diagnostic tests because of a suspected communications problem and have successfully completed the tests without an error message, additional testing may be required on the following:

- Host computer or device with which you are trying to communicate (such as a printer)
- An attached communications device, such as a modem
- Communications cable

To test the IBM ARTIC960RxD PCI Adapter or the Quad T1/E1 DTA, refer to the operating system support programs you downloaded from the Web or BBS (see "Operating System Support" on page 1-9).

If you cannot isolate the problem, have the system unit serviced.

---

### **Diagnostic Testing**

The diagnostic program is designed to prompt you through making a wrap test selection, either to test the Quad T1/E1 DTA using the 36-pin connector at the Quad T1/E1 DTA, or to test one of the ports at the end of the cable.

---

## Diagnostic Wrap Plugs

Table 5-1 lists the part numbers of the wrap plugs used during wrap testing. The part number is printed on the wrap plug.

To test the telephone jack cable, use a short telephone patch cord. Connect the patch cord between the *Transmit (Tx)* and the *Receive (Rx)* connectors of the port you are testing.

<i>Table 5-1. Wrap Plugs</i>	
<b>Description</b>	<b>Part Number</b>
36-pin wrap plug (connector at the adapter)	87H3502
RJ-48 plug cable wrap	87H3588
DB-15 cable wrap plug	34F0876
BNC cable wrap plug (for grounded and ungrounded cables)	61F5394

---

## Chapter 6. Cables and Connectors

Optional cable assemblies (similar to the one in the following figure) are available for the Quad T1/E1 DTA. They are designed to provide four ports of one electrical interface.

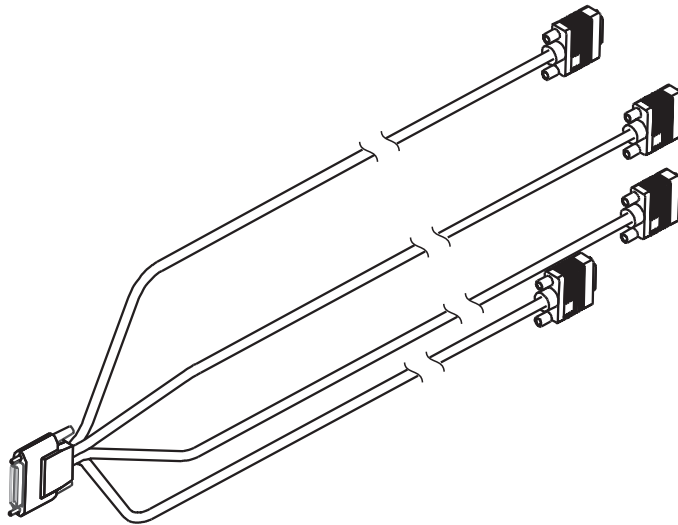

**T1 RJ-48, E1 RJ-48, T1 DB-15, and E1 DB-15**

These cable assemblies consist of a 36-pin male connector at one end of a cable that branches into four individual cables, each of which provides access to one of four independent ports.

**E1 BNC (grounded and ungrounded)**

These cable assemblies split first to four cables. Then, each of the four cables splits into two, resulting in eight connectors. There is a transmit (Tx) connector and a receive (Rx) connector for each of the four ports.

The following table lists the cable name, FRU number, and feature code (FC) number for each optional cable.

<i>Table 6-1. FRU and Feature Code (FC) Numbers for Optional Cables</i>		
<b>Cable Name</b>	<b>Numbers</b>	
	<b>FRU</b>	<b>FC</b>
T1 RJ-48	87H3518	2709
E1 RJ-48	87H3515	2710
T1 DB-15 100 Ohm Balanced	87H3793	2871
T1 DB-15 100 Ohm Extension	54F0740	2872
E1 DB-15 120 Ohm Balanced	87H3791	2873
E1 DB-15 120 Ohm Extension	05F2045	2874
E1 DB-15 120 Ohm Balanced Isolated	47L8826	---
E1 BNC 75 Ohm Unbalanced/Grounded	87H3521	2875
E1 BNC 75 Ohm Unbalanced/Ungrounded	87H3629	2876
4-Drop H.100	08L1215	2877
4-Drop SCBus	08L1217	2878
4-Drop H.100/SCBus Converter	08L1219	2879

Surge protection cables are also available in two versions: RJ-48 (FRU 87H3651) and BNC (FRU 87H3656).

---

## Port Speeds

The Quad T1/E1 DTA supports four ports running simultaneously at a maximum data rate of 2 048 000 bps (bits per second) duplexed. The following table shows the maximum port speed supported for each electrical interface.

<b>Electrical Interface</b>	<b>Maximum Speed (per port)</b>
T1	1 544 000 bps
E1	2 048 000 bps

---

## Connector Pin Numbers and Assignments

This section provides pin numbering and signal assignments for each of the optional cables. For each cable, a table shows the pin assignments for the 36-pin connector and the correlation to the four port connectors. Each signal is identified as input (I) or output (O), as viewed from the Quad T1/E1 DTA.

### 36-pin Connector

The individual signals for all ports connect to the Quad T1/E1 DTA through the 36-pin connector at the rear of the card. The following shows the male 36-pin connector at one end of the cable.

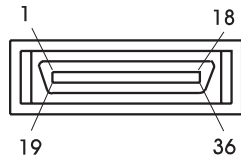

**Note:** A relay on the mezzanine card can be used to generate an external alarm. The standard cables do not provide support for this function. For more information, refer to the technical reference for the IBM ARTIC960RxD Quad Digital Trunk PCI Adapter, which is available on the Web (see "Operating System Support Programs and Publications" on page 2-5).



## RJ-48 Jack Connector

The following illustration shows an RJ-48 jack connector. Table 6-3 lists the pin assignments for the T1 and E1 electrical interfaces. The “x” in the signal name is the number of the port. The ID is 9h for the T1; 1h for the E1.

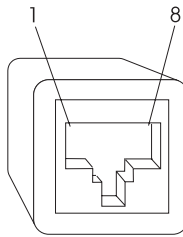
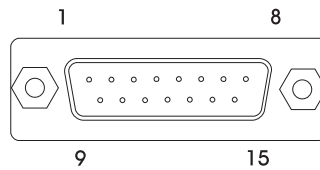

*Table 6-3. RJ-48 Connector Pin Assignments*

Signal Name	I/O	36-pin Connector				RJ-48 Connector
		0	1	2	3	
TX1_x	O	33	29	23	19	04
TX2_x	O	34	30	24	20	05
FGND_x	---	16	12	08	04	06,03
RX1_x	I	35	31	25	21	01
RX2_x	I	36	32	26	22	02
FGND	---	Housing				Housing

## DB-15 Connector

The following illustration shows a DB-15 connector. Table 6-4 lists the pin assignments for the T1 and E1 electrical interfaces. The “x” in the signal name is the number of the port. The ID is 7h for the T1; 2h for the E1.

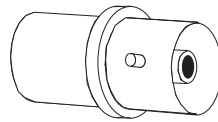

*Table 6-4. DB-15 Connector Pin Assignments*

Signal Name	I/O	36-pin Connector				DB-15 Connector
		0	1	2	3	
TX1_x	O	33	29	23	19	01
TX2_x	O	34	30	24	20	09
FGND_x	---	16	12	08	04	02,04
RX1_x	I	35	31	25	21	11
RX2_x	I	36	32	26	22	03
FGND	---	Housing				Housing, 08, 15

## E1 BNC Connector (Grounded)

The following illustration shows a BNC connector. Table 6-5 lists the pin assignments for the E1 BNC electrical interface. The “x” in the signal name is the number of the port. The ID is 8h for the E1 grounded BNC.



<i>Table 6-5. E1 BNC (Grounded) Connector Pin Assignments</i>						
Signal Name	I/O	36-pin Connector				BNC Connector
		0	1	2	3	
TX1_x	O	33	29	23	19	TX inner conductor RX inner conductor
RX1_x	I	35	31	25	21	
FGND, TX2_x, RX2_x	---	Housing, 20, 22, 24, 26, 30, 32, 34, 36				TX and RX outer conductors

## E1 BNC Connector (Ungrounded)

The following illustration shows a BNC connector. Table 6-6 lists the pin assignments for the E1 BNC electrical interface. The “x” in the signal name is the number of the port. The ID is Ch for the E1 ungrounded BNC.

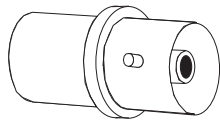

*Table 6-6. E1 BNC Connector (Ungrounded) Pin Assignments*

Signal Name	I/O	36-pin Connector				BNC Connector
		0	1	2	3	
TX1_x	O	33	29	23	19	TX inner conductor
RX1_x	I	35	31	25	21	RX inner conductor
RX2_x	I	36	32	26	22	RX outer conductor
FGND, TX2_x	---	Housing, 20, 24, 30, 34				TX outer conductor

---

## **Appendix A. Communications Statements**

The following statement applies to this product. The statement for other products intended for use with this product appears in their accompanying documentation.

---

### **Federal Communications Commission (FCC) Statement**

**Note:** This equipment has been tested and found to comply with the limits for a Class A digital device, pursuant to Part 15 of the FCC Rules. These limits are designed to provide reasonable protection against harmful interference when the equipment is operated in a commercial environment. This equipment generates, uses, and can radiate radio frequency energy and, if not installed and used in accordance with the instruction manual, may cause harmful interference to radio communications. Operation of this equipment in a residential area is likely to cause harmful interference in which case the user will be required to correct the interference at his own expense.

Properly shielded and grounded cables and connectors must be used in order to meet FCC emission limits. Neither the provider nor the manufacturer are responsible for any radio or television interference caused by using other than recommended cables and connectors or by unauthorized changes or modifications to this equipment. Unauthorized changes or modifications could void the user's authority to operate the equipment.

This device complies with Part 15 of the FCC Rules. Operation is subject to the following two conditions: (1) this device may not cause harmful interference, and (2) this device must accept any interference received, including interference that may cause undesired operation.

---

### **European Union (EU) Statement**

This product is in conformity with the protection requirements of EU Council Directive 89/336/EEC on the approximation of the laws of the Member States relating to electromagnetic compatibility. The manufacturer cannot accept responsibility for any failure to satisfy the protection requirements resulting from a non-recommended modification of the product, including the fitting of option cards supplied by third parties. Consult with your dealer or sales representative for details on your specific hardware.

This product has been tested and found to comply with the limits for Class A Information Technology Equipment according to CISPR 22 / European Standard EN 55022. The limits for Class A equipment were derived for commercial and industrial

environments to provide reasonable protection against interference with licensed communication equipment.

**Attention:** This is a Class A product. In a domestic environment this product may cause radio interference in which case the user may be required to take adequate measures.

---

### **International Electrotechnical Commission (IEC) Statement**

This product has been designed and built to comply with IEC Standard 950.

---

### **United Kingdom Telecommunications Safety Requirements**

This equipment is manufactured to the International Safety Standard EN60950 and as such is approved in the UK under the General Approval Number NS/G/1234/J/100003 for indirect connection to the public telecommunication network.

The network adapter interfaces housed within this equipment are approved separately, each one having its own independent approval number. These interface adapters, supplied by the manufacturer, do not use or contain excessive voltages. An excessive voltage is one which exceeds 70.7 V peak ac or 120 V dc. They interface with this equipment using Safe Extra Low Voltages only. In order to maintain the separate (independent) approval of the manufacturer's adapters, it is essential that other optional cards, not supplied by the manufacturer, do not use main voltages or any other excessive voltages. Seek advice from a competent engineer before installing other adapters not supplied by the manufacturer.

---

### **Avis de conformité aux normes du ministère des Communications du Canada**

Cet appareil numérique de la classe A respecte toutes les exigences du Règlement sur le matériel brouilleur du Canada.

---

### **Canadian Department of Communications Compliance Statement**

This Class A digital apparatus meets the requirements of the Canadian Interference–Causing Equipment Regulations.

---

## VCCI Statement

この装置は、情報処理装置等電波障害自主規制協議会（VCCI）の基準に基づくクラスA情報技術装置です。この装置を家庭環境で使用すると電波妨害を引き起こすことがあります。この場合には使用者が適切な対策を講ずるよう要求されることがあります。

The following is a summary of the VCCI Japanese statement in the box above.

This is a Class A product based on the standard of the Voluntary Control Council for Interference by Information Technology Equipment (VCCI). If this equipment is used in a domestic environment, radio disturbance may arise. When such trouble occurs, the user may be required to take corrective actions.

---

## Electromagnetic Interference (EMI) Statement - Taiwan

### 警告使用者:

這是甲類的資訊產品，在居住的環境中使用時，可能會造成射頻干擾，在這種情況下，使用者會被要求採取某些適當的對策。

The following is a summary of the EMI Taiwan statement above.

Warning: This is a Class A product. In a domestic environment this product may cause radio interference in which case the user will be required to take adequate measures.

---

## Radio Protection for Germany

Dieses Gerät ist berechtigt in Übereinstimmung mit Dem deutschen EMVG vom 9.Nov.92 das EG–Konformitätszeichen zu führen.

Der Aussteller der Konformitätserklärung ist die IBM Germany.

Dieses Gerät erfüllt die Bedingungen der EN 55022 Klasse A. Für diese von Geräten gilt folgende Bestimmung nach dem EMVG:

Geräte dürfen an Orten, für die sie nicht ausreichend entstört sind, nur mit besonderer Genehmigung des Bundesministers für Post und Telekommunikation oder des Bundesamtes für Post und Telekommunikation betrieben werden. Die Genehmigung wird erteilt, wenn keine elektromagnetischen Störungen zu erwarten sind.

(Auszug aus dem EMVG vom 9.Nov.92, Para.3, Abs.4)

### Hinweis

Dieses Genehmigungsverfahren ist von der Deutschen Bundespost noch nicht veröffentlicht worden.

---

## Telecommunications Statements

### FCC Part 68 Compliance Information

The IBM ARTIC960RxD Quad DTA complies with Part 68 of the FCC rules. The label located on the back side of the adapter contains, among other information, the FCC registration number for this equipment. If requested, provide this information to your telephone company. The card has an SOC code of 6.0N and FIC codes 04DU9-BN, 04DU9-DN, 04DU9-IKN, 04DU9-ISN, and 04DU9-IZN.

The IBM ARTIC960 4-Port T1 RJ-48 Cable, which uses USOC jack RJ-48, is an FCC-compliant cable and modular jack available for the adapter. The adapter and cable are designed to be connected to the telephone network or premises wiring using a compatible modular plug that is Part 68-compliant.

If the IBM ARTIC960RxD Quad DTA causes harm to the telephone network, the telephone company may discontinue your service temporarily. If possible, they will notify you in advance. But if advance notice is not practical, you will be notified as soon as possible. You will be advised of your right to file a complaint with the FCC.



Your telephone company may make changes in its facilities, equipment, operations, or procedures that could affect the proper operation of your equipment. If they do, you will be given advance notice so as to give you an opportunity to maintain uninterrupted service.

If trouble is experienced with this equipment, for repair or warranty information, in the United States, call IBM at **1-800-IBM-SERV**. In Canada, call IBM at **1-800-465-6600**.

No repairs can be performed by the customer.

### **Canada Telecommunications Statement**

**NOTICE:** The Industry Canada label identifies certified equipment. This certification means that the equipment meets certain telecommunications network protective, operational and safety requirements as prescribed in the appropriate Terminal Equipment Technical Requirements document(s). The Department does not guarantee the equipment will operate to the user's satisfaction.

Before installing this equipment, users should ensure that it is permissible to be connected to the facilities of the local telecommunications company. The equipment must also be installed using an acceptable method of connection. The customer should be aware that compliance with the preceding conditions might not prevent degradation of service in some situations.

Repairs to certified equipment should be coordinated by a representative designated by the supplier. Any repairs or alterations made by the user to this equipment, or equipment malfunctions, may give the telecommunications company cause to request the user to disconnect the equipment.

Users should ensure for their own protection that the electrical ground connections of the power utility, telephone lines and internal metallic water pipe system, if present, are connected together. This precaution may be particularly important in rural areas.

**Caution:** Users should not attempt to make such connections themselves, but should contact the appropriate electric inspection authority, or electrician, as appropriate.

This equipment uses a CA81A telephone jack.

## **Australian Telecommunications Statement**

### **ATTENTION:**

This card must be connected to TNV Telecommunications equipment or networks using the E1 120 Ohm Balanced DB-15 Isolated cable only. On the 75 ohm connection, the E1 120 Ohm Balanced DB-15 Isolated cable and an ACA approved balun must be used.

## **New Zealand Telecommunications Statement**

### **ATTENTION:** New Zealand Users

The NZ Telecom Telepermit No. PTC 414/98/008 has been issued for direct connection to the Telecom network via its E1 120-ohm balanced interface only. The 75-ohm interface may be used for connection to other equipment (e.g. PBX) but not directly to the Telecom network.

## **Norway and Sweden Telecommunications Statement**

### **ATTENTION:**

This card must only be connected to the Telecommunications Network using the E1 120-ohm Balanced DB-15 Isolated cable.

---

## Index

### Numerics

- 36-pin connector 2-3
- 36-pin D-shell connector 6-4
- 36-pin wrap plug 5-2

### A

- attaching an optional cable 1-8

### C

- cable FRU and part numbers 6-2
- component locations 2-4
- connecting an optional cable 1-8

### D

- data rates, interface 6-3
- DB-15 connector 6-6
- description, base adapter 2-1
- device drivers, installing 1-2
- digital signal processor (DSP) 2-2
- documentation, base adapter 2-5
- downloading diagnostics 1-9
- downloading operating system support 1-9
- DSP (digital signal processor) 2-2

### E

- E1 BNC connector (grounded) 6-7
- E1 BNC connector (ungrounded) 6-8
- EDO DRAM, base adapter 2-2

### F

- FALC (framing and line control) 2-3
- features and function, base adapter 2-2

- framing and line control (FALC) 2-3

### H

- H.100 bus 2-3
- H.100 connector 2-2
- hardware requirements 1-1

### I

- illustration 2-4
- installing device drivers 1-2
- interface port speeds 6-3
- ISO 9000 ix

### J

- jumper positions 1-3

### L

- lightning protection 1-8

### M

- mezzanine card features 2-3
- microprocessor, base adapter 2-2

### O

- operating system support 1-9, 2-5
- optional cables 6-1

### P

- part numbers 2-1
- PMC connector 2-2
- problem determination procedures 5-1

## **R**

related information ix  
removing the mezzanine card 3-1  
RJ-48 cable wrap 5-2  
RJ-48 jack connector 6-5  
ROM, base adapter 2-2

## **S**

specifications 2-5  
synchronous-burst static  
random-access memory  
(SBSRAM) 2-2

## **T**

telecommunications statements A-4  
terminology ix  
trademarks ix  
troubleshooting 5-1  
trunk lines 2-3

## **W**

Web address 1-9, 2-5

---

## Reader's Comments — We'd Like to Hear From You

IBM ARTIC960RxD Quad DTA Installation and User's Guide

Order Number: 41L5825

Overall how satisfied are you with the information in this book?

	Very Satisfied	Satisfied	Neutral	Dissatisfied	Very Dissatisfied
Overall Satisfaction	<input type="checkbox"/>	<input type="checkbox"/>	<input type="checkbox"/>	<input type="checkbox"/>	<input type="checkbox"/>

How satisfied are you that the information in this book is:

	Very Satisfied	Satisfied	Neutral	Dissatisfied	Very Dissatisfied
Accurate	<input type="checkbox"/>	<input type="checkbox"/>	<input type="checkbox"/>	<input type="checkbox"/>	<input type="checkbox"/>
Complete	<input type="checkbox"/>	<input type="checkbox"/>	<input type="checkbox"/>	<input type="checkbox"/>	<input type="checkbox"/>
Easy to find	<input type="checkbox"/>	<input type="checkbox"/>	<input type="checkbox"/>	<input type="checkbox"/>	<input type="checkbox"/>
Easy to understand	<input type="checkbox"/>	<input type="checkbox"/>	<input type="checkbox"/>	<input type="checkbox"/>	<input type="checkbox"/>
Well organized	<input type="checkbox"/>	<input type="checkbox"/>	<input type="checkbox"/>	<input type="checkbox"/>	<input type="checkbox"/>
Applicable to your tasks	<input type="checkbox"/>	<input type="checkbox"/>	<input type="checkbox"/>	<input type="checkbox"/>	<input type="checkbox"/>

Please tell us how we can improve this book:

Thank you for your response. May we contact you?  Yes  No

When you send comments to us, you grant us a nonexclusive right to use or distribute your comments in any way we believe appropriate without incurring any obligation to you.

\_\_\_\_\_  
Name

\_\_\_\_\_  
Address

\_\_\_\_\_  
Company or Organization

\_\_\_\_\_  
Phone Number

Cut or Fold  
Along Line

Fold and Tape

Please do not Staple

Fold and Tape



NO POSTAGE  
NECESSARY  
IF MAILED IN THE  
UNITED STATES

**BUSINESS REPLY MAIL**

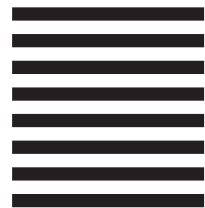

POSTAGE WILL BE PAID BY ADDRESSEE

Information Development  
Department H6DS-9561  
11400 Burnet Road  
Austin, TX 78758-3493



Fold and Tape

Please do not Staple

Fold and Tape

Cut or Fold  
Along Line





Part Number: 41L5825



Printed in the United States of America  
on recycled paper containing 10%  
recovered post-consumer fiber.

41L5825

